



SIZE "1" 80Nm

Performance and Dimensions

MODELS	"BOOM" Length mm	"ARM" Length mm	Pneumatic Balancing Unit Ø mm	Weight Adjustment Range at a pressure of 6 bar Kg.	Reaction Torque Limit Nm	Useful Vertical Stroke mm
S1BP111110000	400	350	32	0-4	80	440
D1BP111110000	400	350	32	0-4	80	440
S1BP111210000	400	350	50	0-10	80	440
D1BP111210000	400	350	50	0-10	80	440
S1BP221110000	550	500	32	0-3	80	640
D1BP221110000	550	500	32	0-3	80	640
S1BP221210000	550	500	50	0-8	80	640
D1BP221210000	550	500	50	0-8	80	640
S1BP331110000	700	650	32	0-2	80	830
D1BP331110000	700	650	32	0-2	80	830
S1BP331210000	700	650	50	0-6	80	830
D1BP331210000	700	650	50	0-6	80	830

Accessories available

Workbench Fastener (standard)	S1BP... D1BP...
Wall Fastener	S1FP... D1FP...
Tool holding clamp is furnished with the arm. Specify diameter of tool when purchasing.	From Ø20 to Ø45



PNEUMATIC WORKBENCH ARTICULATED ARMS

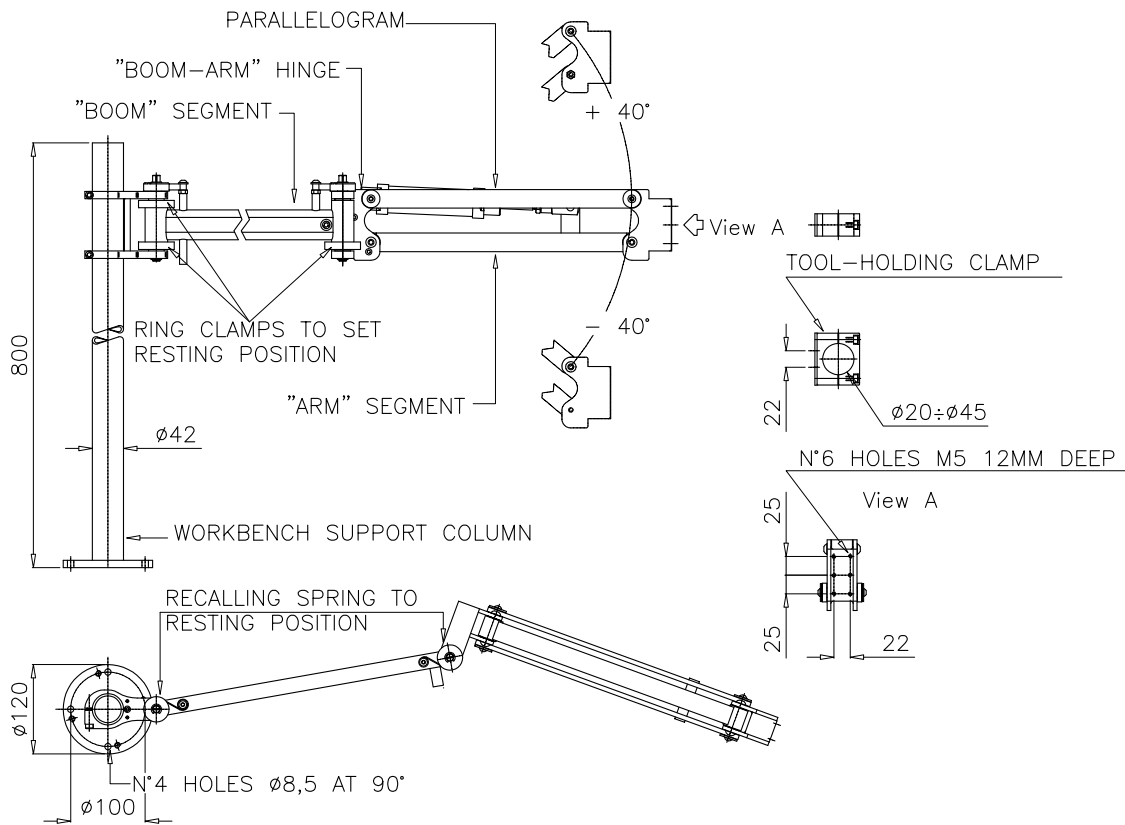
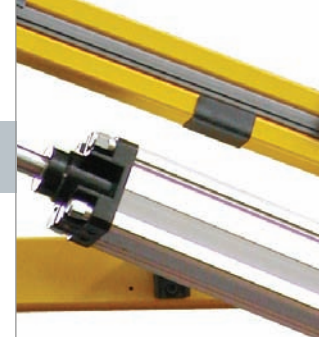

SX (Left) Arm Layout

DX (Right) Arm Layout

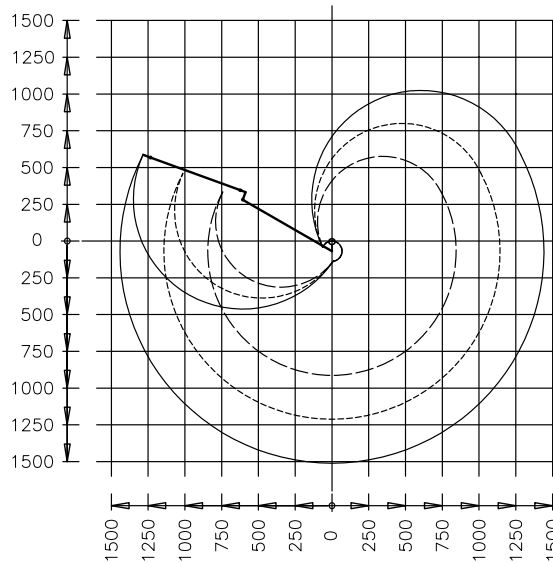
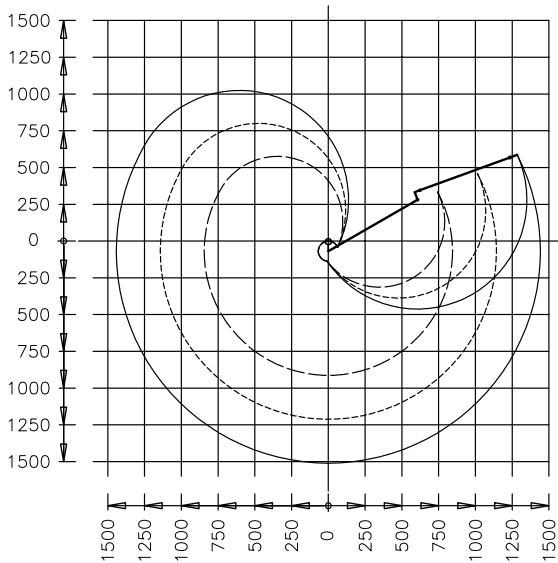

- Boom L-400 Arm L-350
- · - · - · Boom L-550 Arm L-500
- Boom L-700 Arm L-650